

Range waste water

Anti water hammer

ARAA

3000 to 35000 L

The **Hydrochoc waste water** surge vessel with automatic air regulation operates not only as a surge wessel but also as a balancing chimney, without compressor or bladder. Designed for heavily charged or fibrous liquids, it is perfectly adapted to protect flat pipelines often encountered in waste water systems.

MANUFACTURING TO CODAP



PAINT

Internal. Epoxy paint without solvent, colour white, thickness 100 microns.

External. Polyurethane lacquer, colour yellow and anti corrosion polyurethane finishing, thickness 50 microns.



WARRANTY

Not including parts subject to wear and subject to use under normal conditions.



PACKING

Craddles for the vessels.

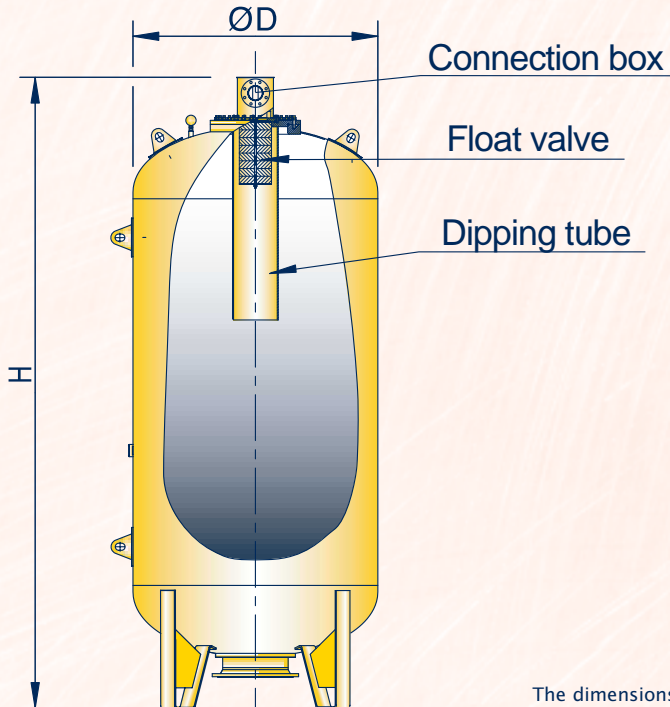

4 holes Ø26 on ØP

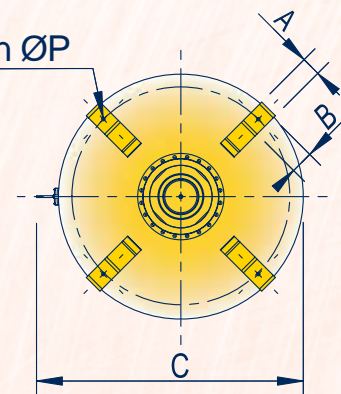

View from underside

Contact us for upper capacities.

The dimensions shown are indicative and can be modified without warning.

Capacity	Ø D (mm)	Height H	P	Size A	Size B	Size C
3000	1200	3600	1050	150	125	1370
4000	1200	4400	1050	150	125	1370
5000	1500	3800	1300	150	178	1670
6000	1500	4600	1300	150	178	1670
7000	1500	5100	1300	150	178	1670
8000	1500	5600	1300	150	178	1670
9000	1900	4800	1700	150	178	2070
9000	2100	3800	1800	150	276	2270
10000	1900	5200	1700	150	178	2070
10000	2100	4100	1800	150	276	2270
12000	1900	5900	1700	150	178	2070
12000	2100	4700	1800	150	276	2270
15000	2100	5600	1800	150	276	2270
20000	2500	5300	2000	500	500	2670
25000	2500	6300	2000	500	500	2670
30000	3000	5700	2550	500	500	3170
35000	3000	6400	2550	500	500	3170